

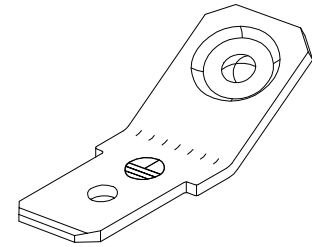

Bu Çizim MESA OTO ELEKTRİK LTD.ŞTİ'nin malıdır. Şirket Yetkililerinin izni olmaksızın kopya edilemez, üzerinde değişiklik yapılamaz.  
This Drawing MESA AUTO ELECTRIC LTD 's are property. Can not be copied without the consent of the company authorized, any changes can be made.

PARÇA KODU PART CODE	PARÇA ADI PART NAME	s ÖLÇÜSÜ (KALINLIK) s MEASURE (THICKNESS)	Malzeme Material	Kaplama Coating
TSAC 1902 DS	6.3 - 45° ERKEK FİŞ PUNTALI =DS=	—	DKP SAC	—
TSAC 1902 DSN	6.3 - 45° ERKEK FİŞ PUNTALI =DSN=	—	DKP SAC	Nikel / Ni (3-5µ)

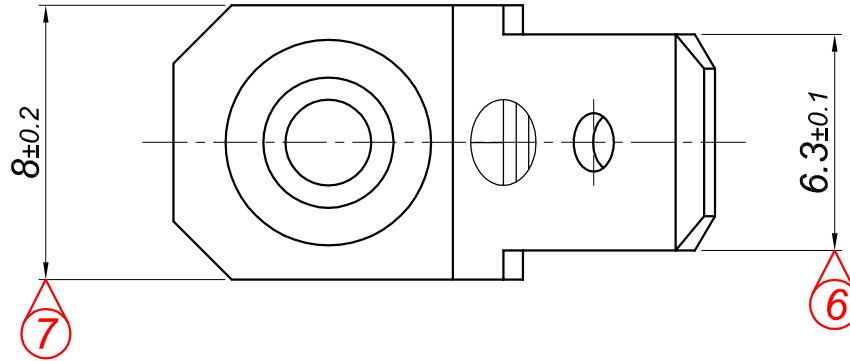
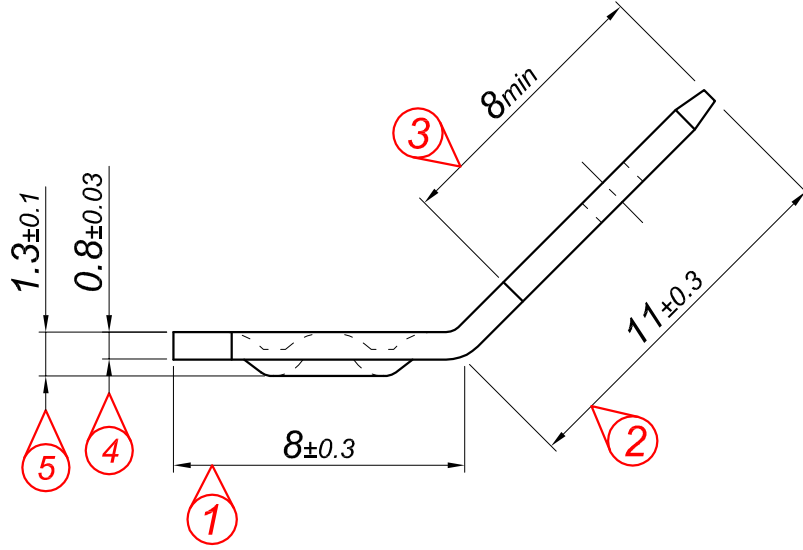

Resim üzerinden ölçü almayınız  
do not measure on drawing

Tarih / Date	11.12.2013	İmza /Signature	Ölçek /Scale			
Çizen / Desing	M.Yağcı					
Onay / Approval	S.Gölcük		5 / 1	No	Değişiklik / Revision	Tarih/Date
	Parça Adı: Part Name	6.3 - 45° ERKEK FİŞ PUNTALI			Parça Kodu: Part Code	TSAC 1902